

Specialists in Gravimetric Blending & Control

OPTIX 100

Gravimetric Batch Blender with
Loss-in-Weight Extrusion
Control



In line with growing demand for our **OPTIX** range, we have released the new **OPTIX 100** series which can deliver up to 100 Kilos (220 lbs.) per hour for continuous machine direction control of extrusion processes. This expansion allows **TSM** to offer a very compact unit ideal for multi-layer co-ex applications. **TSM**'s patented reverse auger technology is combined with ultra-fast, responsive throughput measurements for real-time control. A new control algorithm allows performance to be maintained at lower set-points. The unique mechanical design delivers a small footprint, making it ideal for either new multi-layer extrusion lines or retrofit installations with 4 or 6 Material Components as options.

TSM

Benefits

- High Accuracy Dispensing up to 0.01% of Batch
- Instantaneous Response to Process Disturbances
- Superior Weighing & Mixing with Fast Throughput Measurement
- Enhanced Closure Designs – New catches & Door Frame
- New Sight Glass on Bins

User Interface

- Enhanced Connectivity for Data Access – Insight Ready
- New Control Algorithm for faster Accurate Control Response
- Intuitive Operator Functionality
- Comprehensive Report/Alarm Management
- Built-in Trending & Data History Management

OptiX Options

- Extrusion Yield Control
- Integrated Material Handling
- Micra-Dose Additive Feeder
- Material Bypass

6 Component Option



www.tsm-controls.com



OPTIX 100

Multi Component Gravimetric Batch Blender for EXTRUSION Control

Characteristics	OPTIX 100
Reservoir Hopper Volume / Compartment (lt/cuft)	15 / 0.5
Standard Number of Components	4
Optional Additional Dosing Stations	2
Std Batch Weight Capacity (kg)	1
Mixing Motor Ø	1
Motor kW / HP)	0.25 / 0.18
Blender Weight kg / Lb	60 / 132
Max Material Temp °C / °F	70 / 158
Max Optional Material Temp °C / °F	130 / 266

Dimensions	
A Blender Height (mm / ins)	936.5 / 36.9
B Frame Height (mm / ins)	559 / 22
C Hopper Bin Front Width (mm / ins)	640 / 25.2

Standard Dimensions

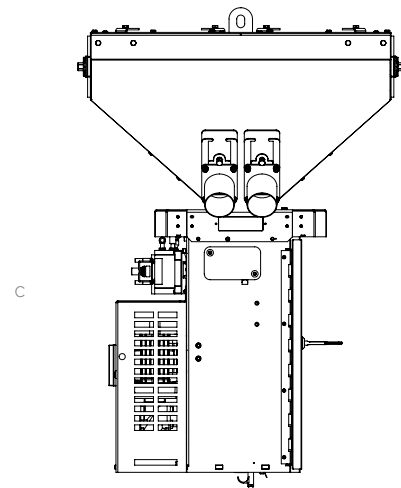
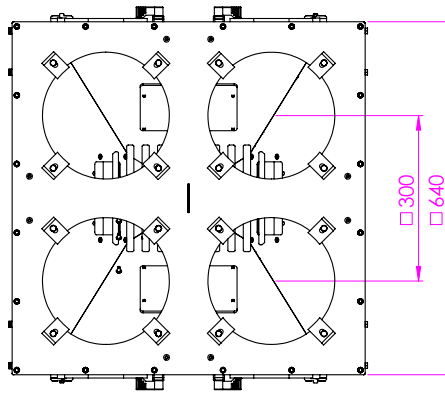
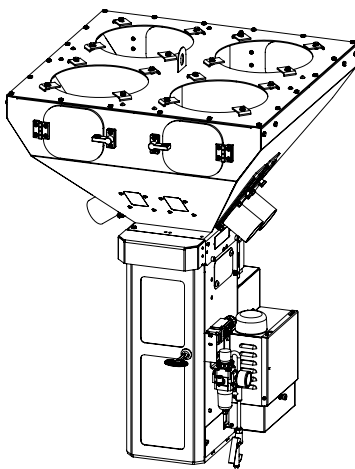
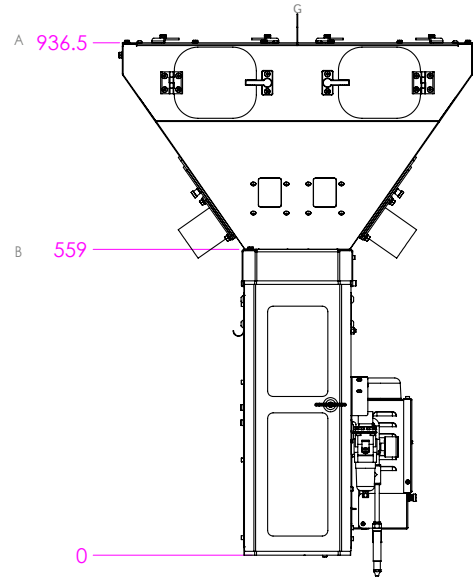

European Office

TSM
Ard Easmuinn, Dundalk,
Co. Louth, Ireland.

Tel: +353-42-9335560
Fax: +353-42-9334422

General Info:
info@tsm-controls.com
Sales:
sales@tsm-controls.com
Support:
service@tsm-controls.com

North America Regional Offices

TSM Inc.
1505 Johnson Ferry Road
Marietta, GA 30062, USA.

Tel: (770)886-6630
Fax: (770)886-2395

General Info:
info@us.tsm-controls.com
Sales:
sales@us.tsm-controls.com
Support:
service@us.tsm-controls.com

TSM Inc.
1404 Joliet Road
Romeoville, IL 60446, USA.

Asia-Pacific Regional Office

TSM Taiwan
Siangshang Street
Taichung City, Taiwan,

Tel: +886-4-24728185
Fax: +886-4-24728180

General Info:
info@tsm-controls.com.tw
Sales:
sales@tsm-controls.com.tw
Support:
service@tsm-controls.com.tw

China Regional Office

TSM China
Office Tower, China Hotel
122 Lihua Road, Guangzhou, China

Tel: +86-20-86266016
Fax: +86-20-86266015

General Info:
china@tsm-controls.com
Sales:
china@tsm-controls.com
Support:
china@tsm-controls.com