

Blending | Controls | Analytics

VACUUM RECEIVERS



As material loading is an integral part of every production process, minimal disruption of material flow with complete control is essential. TSM offers a range of reliable and user-friendly **Vacuum Receivers** to serve your material handling needs up to 115 ltrs /4cuft.

TSM

Benefits

- Low Maintenance Due to Patented Automatic Blow-Down Screen Filter Cleaning
- Stainless Steel Contact Surfaces
- Reliable Material Flow
- Quick Release Mechanisms allow Effortless Dismantling
- Interchangeable Line Size Adaptors
- Separate On/Off Switch
- Inspection Door
- Modular Construction for Maximum Flexibility

User Interface

- Easy installation:
 - No Protruding Parts therefore no Intrusion into Blender Reservoir
 - Fully Directional Mounting Flange makes Installation Quick and Simple
- Effortless dismantling:
 - Quick Release Inspection Mechanism for Easy Access
 - Easy Dismantling for Accessing the Vacuum Receiver without Tools
- Easy Cleaning:
 - Automatic Filter Cleaning and Material Blow-Down by Compressed Air Pulse
 - Filter can be Replaced in Seconds without Tools

Options

- Stainless Steel Vacuum Manifolds
- Anti-Static flex Tubing
- Pick-up wands
- Heavy Duty Vacuum Breaker Valve



VACUUM RECEIVERS

Model	TVR-6	TVR-10	TVR-15	TVR-35	TVR-50	TVR-85	TVR-115
Capacity (lt/cuft)	6 / 0.2	10 / 0.35	15 / 0.5	35 / 1.2	50 / 1.7	85 / 3.0	115 / 4.0
Height 'A' (mm/ins)	585 / 23.0	715 / 28.2	640 / 25.2	942 / 37.1	1142 / 45.0	1247 / 49.1	1412 / 55.6
Body Dia 'B' (mm/ins)	227 / 9	227 / 9	300 / 11.8	300 / 11.8	300 / 11.8	500 / 19.7	500 / 19.7
Flange Dia 'C' (mm/ins)	254 / 10	254 / 10	327 / 12.9	327 / 12.9	327 / 12.9	327 / 12.9	327 / 12.9
Weight (kg/lbs)	8.9 / 19.6	10.0 / 21.9	11.6 / 25.6	14.0 / 30.9	16.4 / 36.2	18.8 / 41.5	21.7 / 47.8
Line Size Adaptors*	51 / 63mm 2.0 / 2.5ins	51 / 63 / 76mm 2.0 / 2.5 / 3.0ins	51 / 63 / 76mm 2.0 / 2.5 / 3.0ins	51 / 63 / 76mm 2.0 / 2.5 / 3.0ins	51 / 63 / 76mm 2.0 / 2.5 / 3.0ins	51 / 63 / 76mm 2.0 / 2.5 / 3.0ins	51 / 63 / 76mm 2.0 / 2.5 / 3.0ins

* More Line Size adaptor options available on request

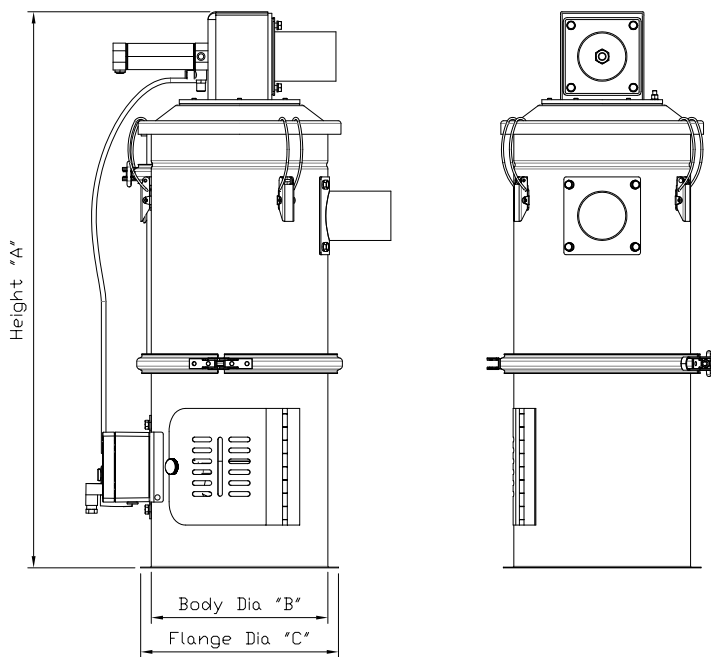

European Office

TSM
Ard Easmuinn, Dundalk,
Co. Louth, Ireland

Tel: +353-42-9335560
Fax: +353-42-9334422

General Info:
info@tsm-controls.com
Sales:
sales@tsm-controls.com
Support:
service@tsm-controls.com

North America Regional Offices

TSM Inc.
1505 Johnson Ferry Road
Marietta, GA 30062, USA

Tel: (770)886-6630
Fax: (770)886-2395

General Info:
info@us.tsm-controls.com
Sales:
sales@us.tsm-controls.com
Support:
service@us.tsm-controls.com

TSM Inc.
1404 Joliet Road
Romeoville, IL 60446, USA

Asia-Pacific Regional Office

TSM Taiwan
Siangshang Street
Taichung City, Taiwan

Tel: +886-4-24728185
Fax: +886-4-24728180

General Info:
info@tsm-controls.com.tw
Sales:
sales@tsm-controls.com.tw
Support:
service@tsm-controls.com.tw

China Regional Office

TSM China
Room 2423, IPC Center, No. 983
East HuangPu AVE, HuangPu District
GuangZhou City 510000, China

Tel: +86-20-86266016
Fax: +86-20-86266015

General Info:
china@tsm-controls.com
Sales:
china@tsm-controls.com
Support:
china@tsm-controls.com