

Specialists in Gravimetric Blending & Controls

# OPTIBLEND

Multi Component  
Continuous LIW Blending



**TSM's OPTI-BLEND** range of Continuous blending solutions offer total reliability, precision and process control options ensuring material homogeneity and guaranteeing consistent product quality. They provide continuous gravimetric and throughput control of up to seven components. The OPTI-BLEND controls the blend percentages and can also maintain the extruder throughput at a desired level, i.e. kg/hr control.

Haul off speed measurement can be added to ensure that the weight per length is controlled to the desired specification (yield control). This ensures that the product being produced is maintained at the desired thickness without operator intervention. This mode can be extended to weight per area control through entry, or automatic measurement of material.

The TSM OPTI-BLEND provides a "dosing" solution to gravimetric blending and extrusion control for up to 7 components. The primary component is gravity fed directly to the extruder throat and the secondary (side fed materials) maintain recipe ratio via auger feeds.

# TSM

## Benefits

- No Material Separation or De-mixing
- Product Consistency
- High Accuracy Dosing up to 0.01%
- Reduce Scrap from Off-Spec Products
- Starve-fed or Flood-fed Applications
- Gravity Fed Main Component allows Recipe Changes "On the Fly"
- Easily Removable, Easy Clean, augers

## User Interface

- Intuitive Simple Operator Functionality
- Comprehensive Report/Alarm Management
- Built-in Accuracy Trending & Data History Management
- Industry Standard Communication Protocols
- Material Usage/Inventory Statistics & Reports

## Options

- 1 – 7 Dosing Stations
- Extruder Kg/Hr Control
- Weight per Length Control
- Offline Blending
- Micro-Dosing



Specialists in Gravimetric Blending & Controls

# OPTIBLEND

## Multi Component Continuous LIW Blending

OPTI-BLEND RANGE	THROUGHPUT
OPTI-BLEND 400	400 kg (880 lbs) / hour
OPTI-BLEND 1000	1000 kg (2200 lbs) / hour
OPTI-BLEND 1800	1800 kg (3960 lbs) / hour

### Environmental

Blender Weight	(kg / lb)	250 / 550
Max Ambient Operating Temp	(°C / °F)	50 / 122
Max Material Temp	(°C / °F)	70 / 158
* Max Optional Material Temp	(°C / °F)	130 / 266

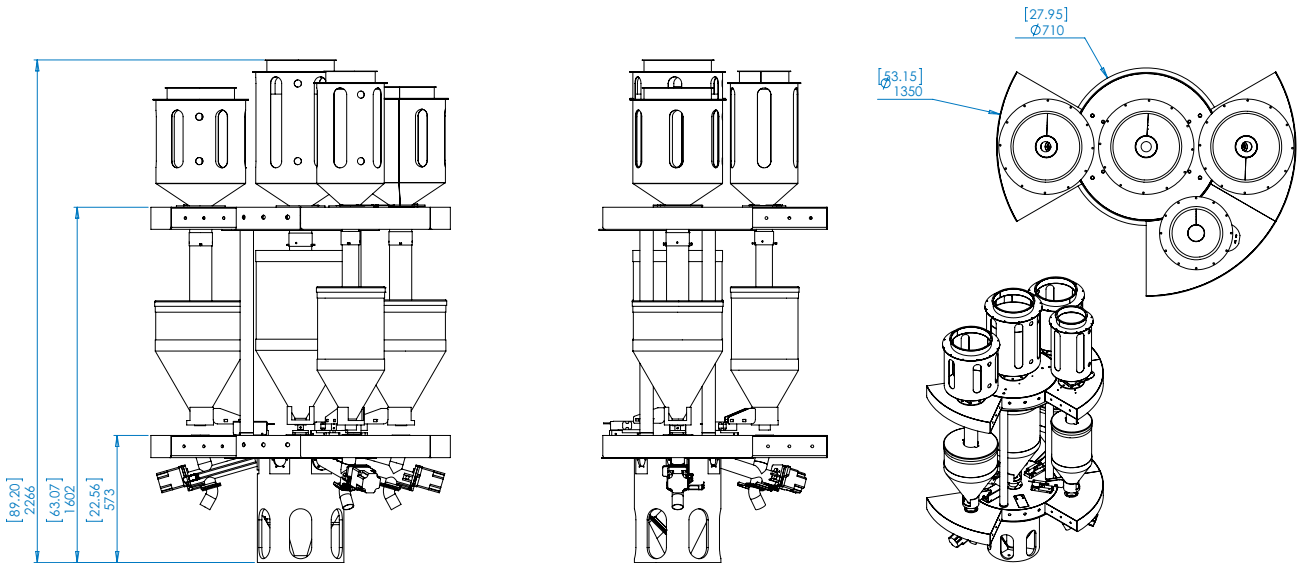

#### European Office (Headquarters)

**TSM**  
Ard Easmuinn, Dundalk,  
Co. Louth, Ireland.

**Tel:** +353-42-9335560

**General Info:**  
info@tsm-controls.com  
**Sales:**  
sales@tsm-controls.com  
**Support:**  
service@tsm-controls.com

#### North America Regional Offices

**TSM Inc.**  
1505 Johnson Ferry Road  
Marietta, GA 30062, USA.

**TSM Inc.**  
1404 Joliet Road,  
Romeoville, IL 60446, USA.

**Tel:** (770) 886-6630

**General Info:**  
info@us.tsm-controls.com  
**Sales:**  
sales@us.tsm-controls.com  
**Support:**  
service@us.tsm-controls.com

#### Asia-Pacific Regional Office

**TSM Taiwan**  
Taichung City, Taiwan,

**Tel:** +886-4-24728185

**General Info:**  
info@tsm-controls.com.tw  
**Sales:**  
sales@tsm-controls.com.tw  
**Support:**  
service@tsm-controls.com.tw

#### China Regional Office

**TSM China**  
Room 2423, IPC Center, No. 983,  
East HuangPu AVE, HuangPu District,  
GuangZhou City 510000, China.

**Tel:** +86-139-25062596

**General Info:**  
china@tsm-controls.com  
**Sales:**  
china@tsm-controls.com  
**Support:**  
china@tsm-controls.com