



Solutions Through Partnership

Complete Turnkey Solutions

There are many challenges facing Plastic producers including energy, material costs, waste & scrap reduction, higher productivity, consistent quality and inventory management.

TSM is working with our customers to address these challenges and can offer a complete solution to plastic producers utilizing our full range of products and over 40 years of expertise.

Of primary importance to producers is the quality and uniformity of the final product. TSM's overall solution; from silos through to the process, providing producers with a single source for all material handling and axillary equipment requirements.

- Silos
- Railcar Unloading Systems
- Surge Bins
- Gaylord Tilters
- Box Dumpers
- Vacuum Receivers
- Material Handling Systems
- Gravimetric Blending
- Extrusion Control
- Central Line Control System
- Automatic Air Ring
- Automatic Thickness (gauge) Control
- Bubble Sizing Cages
- Dryers

www.tsm-controls.com



European Office (Headquarters)

TSM

TSM Control Systems,
Finnabair Industrial Estate,
Dundalk, Co. Louth,
Ireland

Tel: +353-42-933-5560

Email:
General: info@tsm-controls.com
Sales: sales@tsm-controls.com
Support: service@tsm-controls.com

North America Regional Office

TSM Inc.

1505 Johnson Ferry Road,
Marietta, GA 30062, USA

1404 Joliet Road,
Romeoville, IL 60446, USA

Tel: (770)-886-6630

Email:
General: info@us.tsm-controls.com
Sales: sales@us.tsm-controls.com
Support: service@us.tsm-controls.com

Asia-Pacific Regional Office

TSM Taiwan

No.13 Siangshang 1st Street,
West District,
Taichung City 403,
Taiwan

Tel: +886-4-2472-8185

Email:
General: info@tsm-controls.com.tw
Sales: sales@tsm-controls.com.tw
Support: service@tsm-controls.com.tw

China Regional Office

TSM China

Room 2423, No. 983, International Port
Center (IPC), HuangPu Avenue (East),
HuangPu District, GuangZhou City,
China

Tel: +86-139-2506-2596

Email:
General: china@tsm-controls.com
Sales: china@tsm-controls.com
Support: china@tsm-controls.com



Solutions Through Partnership



Complete Turnkey Solutions



www.tsm-controls.com

Complete Turnkey Solutions

TSM

Solutions Through Partnership

1 Gravimetric Blending

Opti-Mix range of blenders provide superior accuracy, blend ratios and mixing homogeneity. Opti-Mix blenders utilize TSM's patented technologies in slide valve design and reverse flighted auger mixing. Opti-Mix range can accommodate throughputs up to 3,000kg/hr (6,600lbs/hr).

- High accuracy dispensing to 0.01% of batch
- Superior weighing and patented mixing
- Throughput and weight / length extrusion control options
- Material usage / inventory statistics
- Extrusion control accuracy up to +/- 0.5% of target setpoint

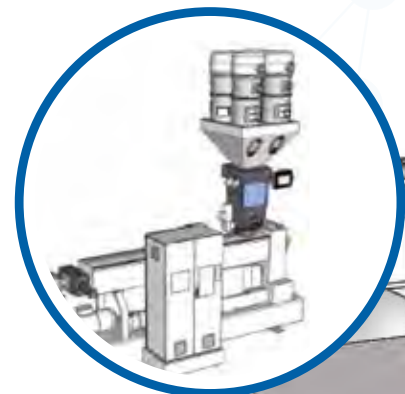

2 Vacuum Receivers

- 0.2 to 6 cuft capacities
- Stainless steel contact surfaces
- Dedicated and common material line
- High heat optional
- Modular construction for maximum flexibility



3 Extrusion Control

TSM has continually invested in best in class extrusion control technologies, which allow's TSM to bring to market the fastest and most accurate control technologies available on the market. Incorporated as standard in the OPTI-X extrusion control blender, producers can choose from: Throughput Control – varying the extruder speed to control output rate. Weight per Length Control – maintains product yield by adjusting the Extruder or Extruder and/or Haul-off speeds simultaneously.

- Improved quality
- Fast start up
- Reduce material usage
- Less waste
- Simple intuitive operator interface
- Comprehensive reporting
- Compensates for bulk density variations
- Tighter tolerances achievable



Complete Turnkey Solutions

4 Railcar Unloading

- Modular or Push-Pull Systems
- Cyclone & Filter Receivers
- Custom Manifolds
- Transfer Stations
- Rotary Airlocks
- Rates 5,000-100,000 Lb/hr

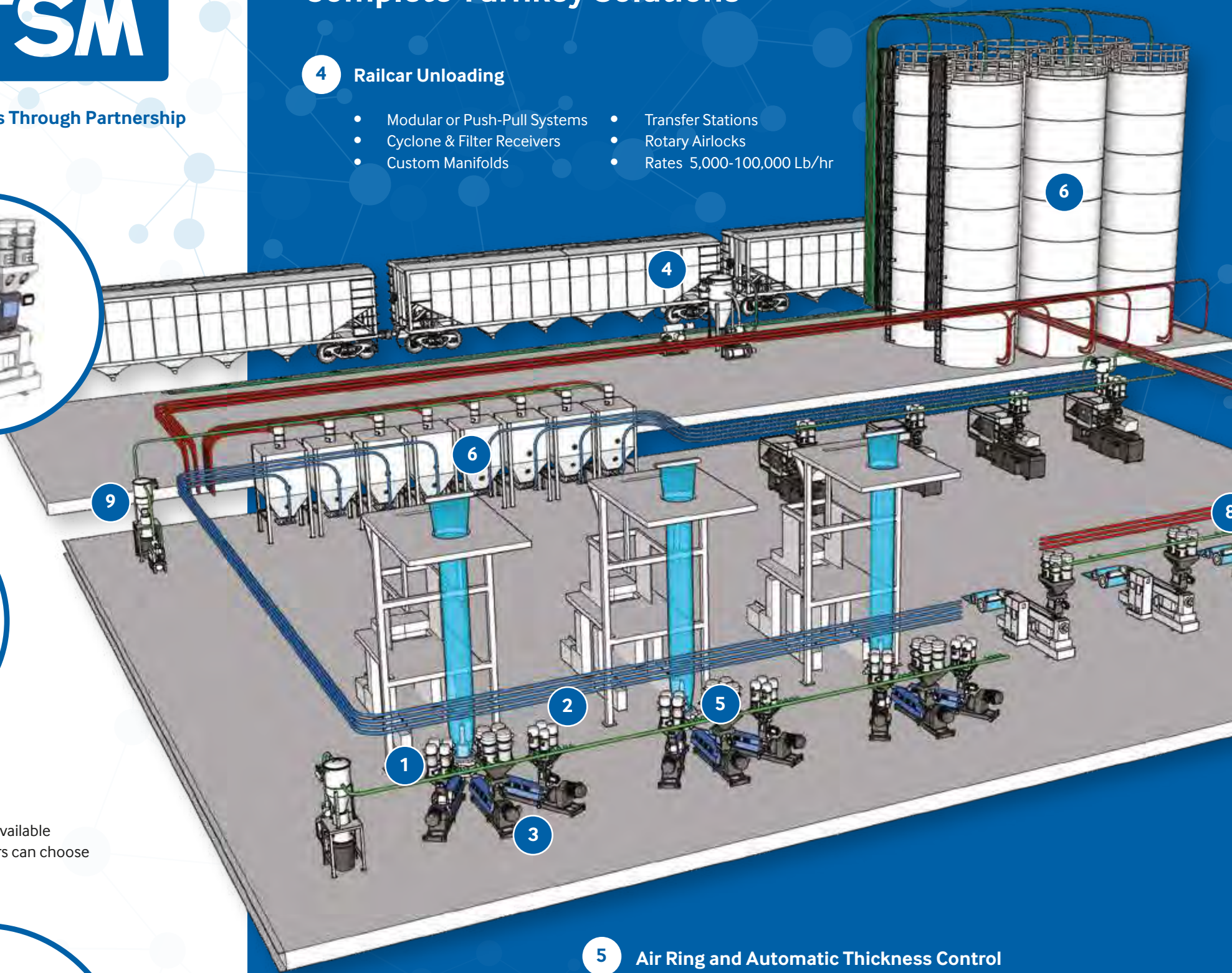

5 Air Ring and Automatic Thickness Control

TSM Control Systems, in collaboration with Octagon, is proud to present the SmartLip One AirRing, a significant leap forward in blown film control technology. Engineered to provide unparalleled film quality and production efficiency, SmartLip One is the choice for forward-thinking manufacturers aiming for the pinnacle of performance and sustainable solutions for the cross directional film profile.

SmartLip ONE is an improved design based on very reliable and unique technology but now with the added benefit of just one air inlet and integrated insulation. It offers a significant increase in output, vastly improved thickness tolerances, less condensation and low-pressure consumption. The mechanical design of the air chamber and flow channels gives the air-ring a unique edge over competitive systems for better control of the bubble geometry and stability. The rigorous development of the air ring is based on substantial fluidic studies & thorough practical tests, along with significant input from customers.

6 Custom Silos

- Bulk Material Storage for storage of Shipped Resin
- 40,000 Lb up to 250,000 Lb
- Welded, Bolted or Corrugated Silos
- Carbon Steel, Stainless Steel or Aluminum
- Standard Cone Design 45 & 60 Degree
- Point Level Sensors, High & Low Level Alarms
- Full Installation Services
- 10 Degree Top Slope
- Continuous Level Sensors
- Angel Hair Traps
- Load Cells
- Vacuum Take-Off Boxes
- Magnets
- Air Pads



7 Surge Bins

- Custom capacities
- Aluminum, Stainless Steel & Carbon Steel
- Standard Cone Design 45 & 60 Degree
- Point Level Sensors, High & Low Level Alarms
- Angel Hair Traps
- Vacuum Take-Off Boxes
- Magnets
- Air Pads



8 Pneumatic Conveying

- Vacuum & Material Lines
- Aluminum, Stainless Steel & Carbon Steel
- Tubing 1" to 14" OD
- Elbows, Laterals, Wyes, Couplers, etc.
- Anti-Static Flexible Hose 1" to 10" ID
- Dedicated and Common Material Lines
- Sizing & Installation
- Custom Manifolds



9 Positive Displacement Pump Packages

- Vacuum & pressure pumps available
- 3 - 60 HP TEFC MOTORS
- 500 - 50,000 Lb/hr capacities
- Positive displacement lobe blower
- Inlet safety filter standard
- Exhaust filter and silencer standard
- Liquid filled vacuum gauge standard
- Optional sound enclosures
- Central dust collection
- Pump, filter & material lines sized for application

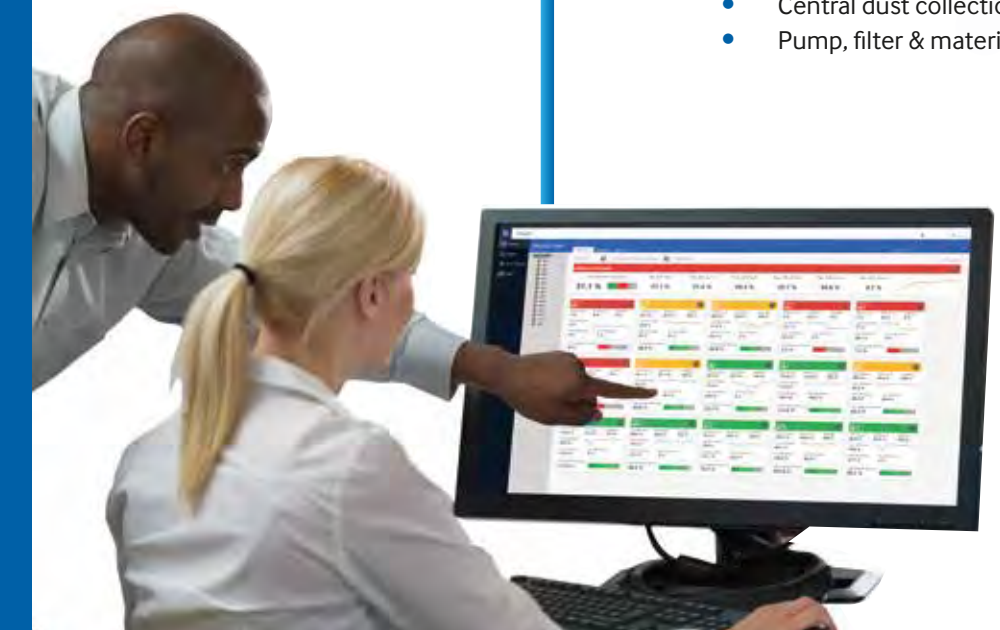

TSM

Solutions Through Partnership